



INDOOR DISPLAY

USER MANUAL

MODEL: 75"

SKU: DGYW75

75"



Thank you for purchasing this product from Slimline Warehouse

It's our mission to help you connect with the world and build your brand with products that are personalized to your needs.

Your product has been manufactured with great care using only the finest quality materials and expert workmanship. Our Quality Assurance team inspects all electronics during assembly process to assure reliable operation. This product comes with a 12-month warranty. Scan the QR code to visit the product page and learn more about your warranty.

Need assistance? We are available for expert advice and all of your customer service needs.

We're Here To Assist



1300 658 808



www.slimlinewarehouse.com.au



support@slimlinewarehouse.com.au

TABLE OF CONTENTS

BEFORE USE

Safety Warnings and Precautions	4
Packing List	5
Parts Diagram	6
Assembly	7

OPERATION

Power On/off	10
HDMI Connection	11
Remote Control	12
Menu Navigation	13
Quick Start Guide	13

REFERENCE

Technical Specifications	15
Cleaning and Maintenance	16
Troubleshooting Guide	17



BEFORE USE

Safety Warnings and Precautions

Based on the product design and LCD properties, the following safety measures must be observed during the handling and use of the device:

- Avoid high temperatures and high humidity environments: The operating temperature range is 0~40°C, and the operating humidity range is 10%~90%.
- Suitable operating time: The device is rated to be used for no more than 18 hours a day.
- Use suitable voltage input: The device supports a voltage range of 100~240V. Excessive voltage can damage the device.
- Avoid exposure to strong electromagnetic environments: Strong electromagnetic waves can damage the device.
- Ensure proper ventilation: Operate the device in a well-ventilated environment for optimal performance.
- Avoid excessive vibration, heavy drops, and severe impacts: Such conditions can cause damage to the device.
- Do not attempt to replace or modify components yourself. We will not be held responsible for any damage or injury caused by unauthorised modifications.
- Perform regular cleaning: Routine cleaning helps maintain proper device operation. Before cleaning the Digital Signage, please pull out the power plug, wipe with soft cloth, do not use industrial chemicals, prevent foreign matters from entering the machine. Improper cleaning (such as cleaning solution, water) may damage the product, erase the printed information, and even cause damage of the components if fluid flows in, resulting in machine failure.

Packing List

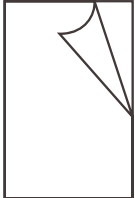
ACCESORY	PHOTO / REFERENCE	QTY	REMARK
Remote Control (And USB Dongle)		1	(Dongle has to be inserted into a usb port on the display for remote to work) Dongle can be located in battery compartment of the remote
Power Cord (1.8m)		1	
User Manual		1	

Parts Diagram

Model: 75" (SKU: DGYW75)

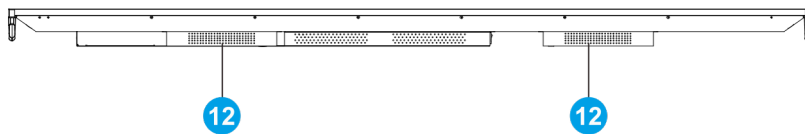
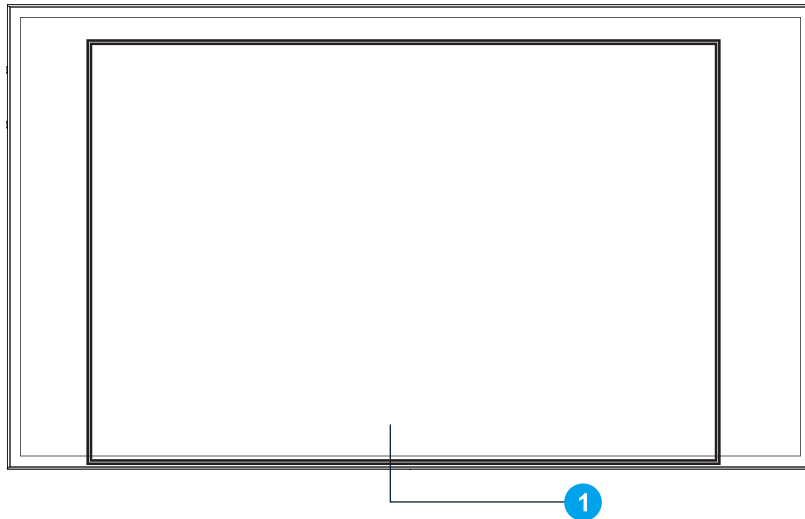
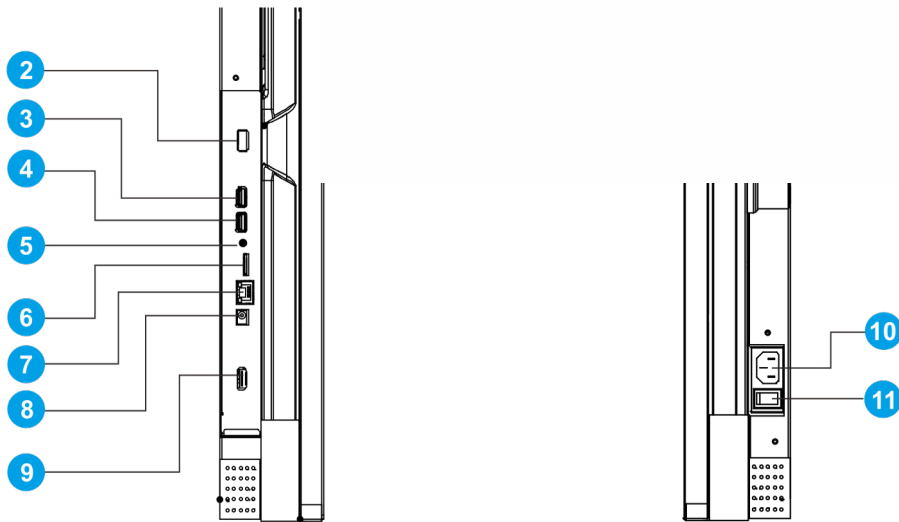

- | | | |
|---------------------|-------------------------|------------------|
| 1 LCD Screen | 6 TF(Micro SD) Port | 11 On/off Switch |
| 2 USB 2.0 Port | 7 RJ45 Port | 12 Speaker |
| 3 USB 2.0 Port | 8 AC Power Cord | |
| 4 USB 3.0 Port | 9 HDMI-IN Port | |
| 5 Audio Output Port | 10 AC Power Cord Socket | |

Assembly (75")

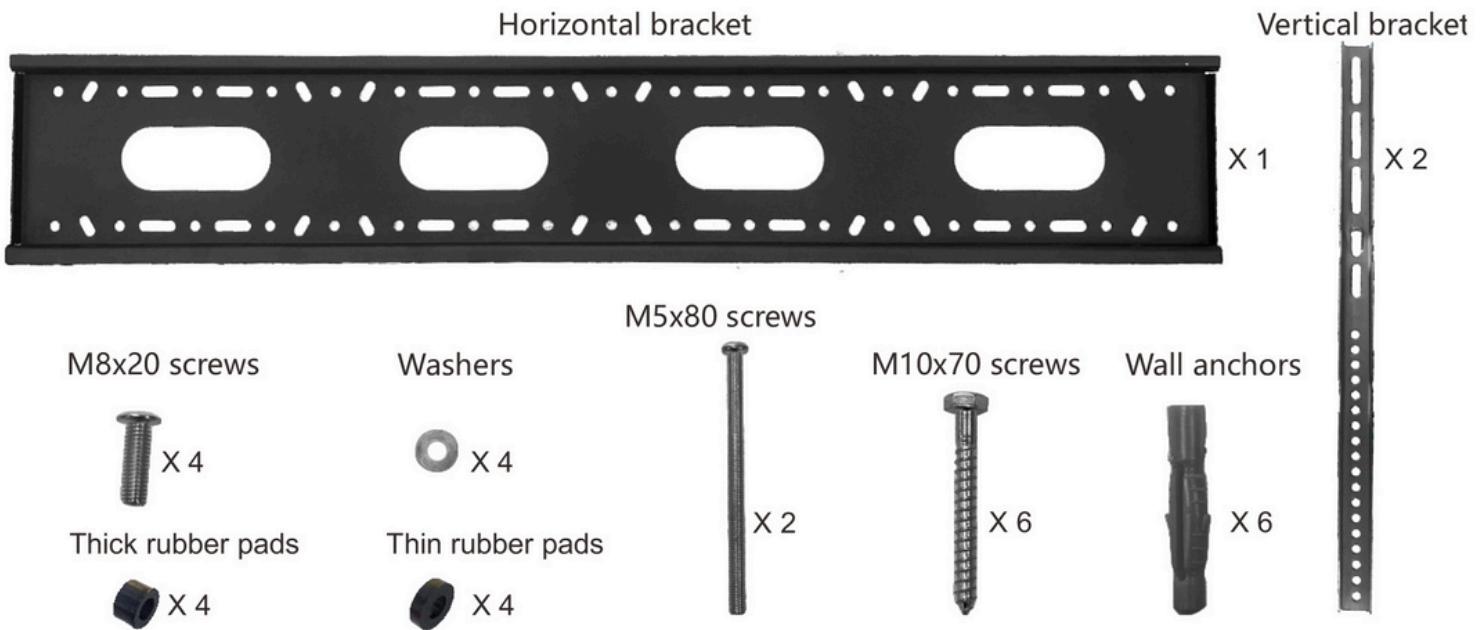

Installation steps:

1. Select the installation wall position. Press the horizontal bracket against the wall and use a marker to mark all six screw holes as shown in the diagram below.

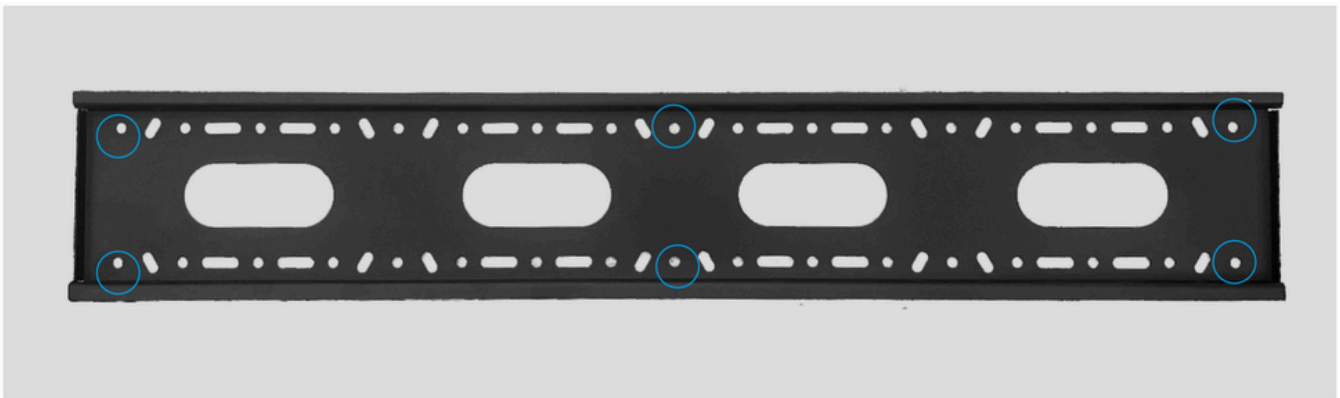

2. Drill six holes at the marked positions using an electric drill, then tap the wall anchors into the wall.

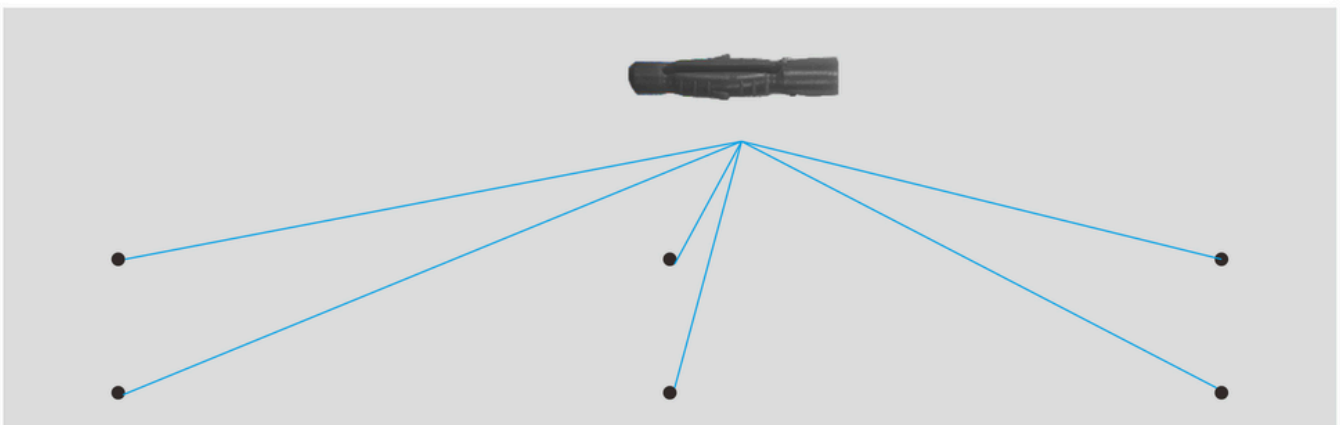

3. Secure the horizontal bracket to the wall using six M10x70 screws as shown in the diagram below.

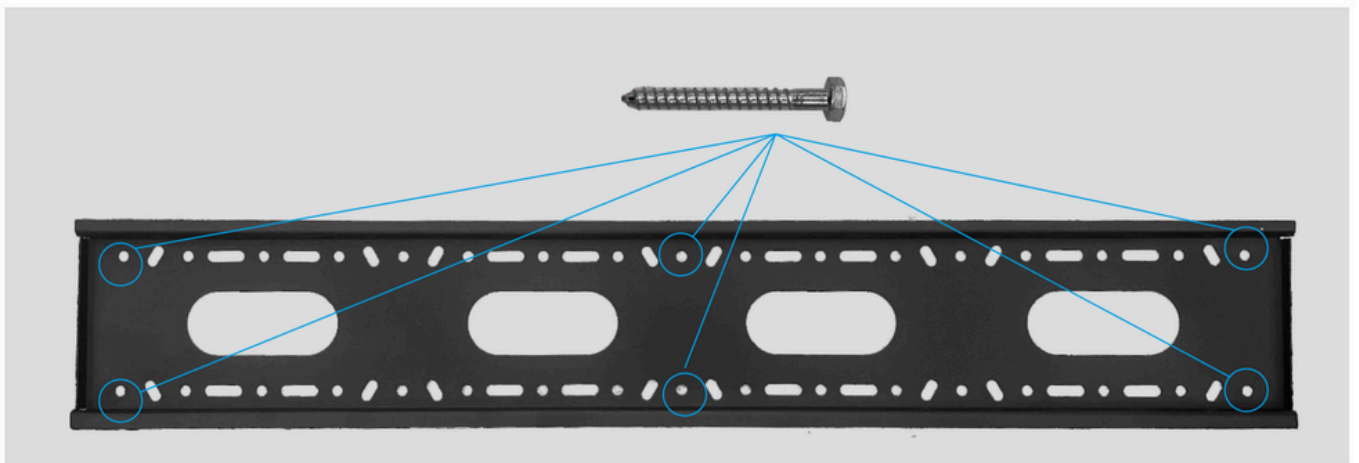

4. Attach the two vertical brackets to the back of the LCD unit at the four mounting holes using four M8x20 screws, as illustrated below.

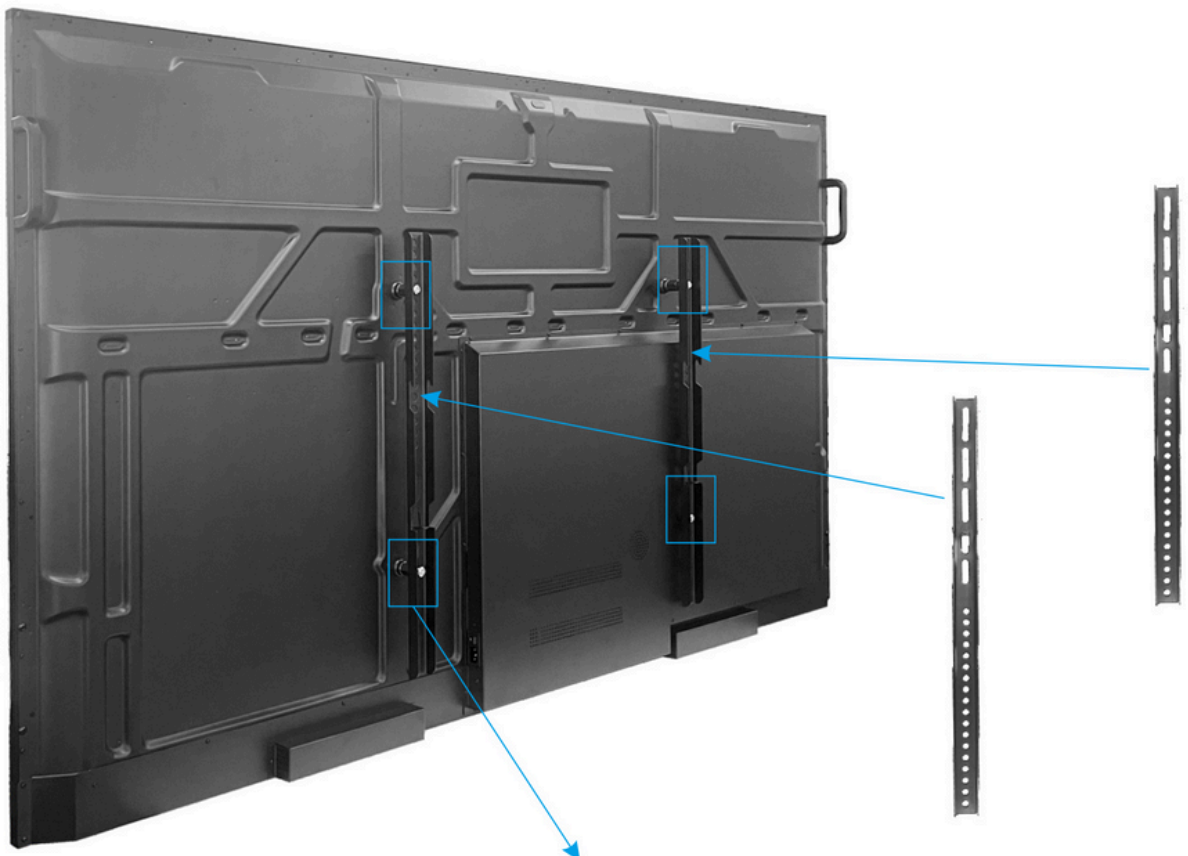

To prevent the screws from being too long, select either thick or thin rubber pads as needed.



5. Insert two M5x80 screws into the vertical brackets as shown in the diagram below.

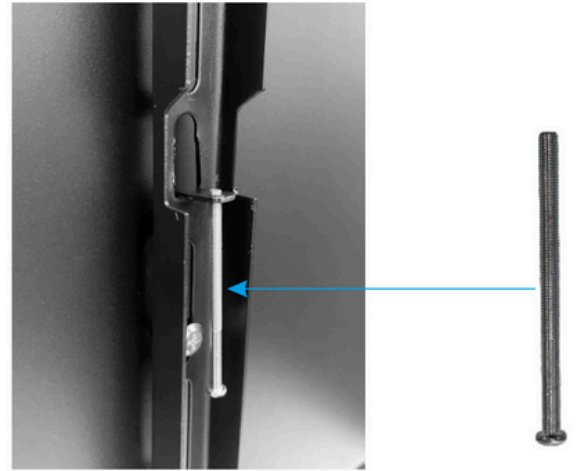
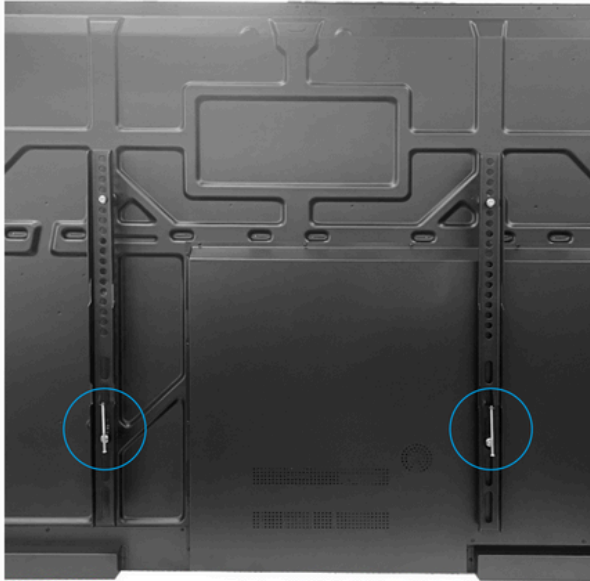

6. Hang the 75-inch LCD unit on the wall, adjust its position, and then tighten the M5x80 screws until they press firmly against the horizontal bracket. Installation is now complete. Plug in the power cable, switch on the unit, and the content will start playing.

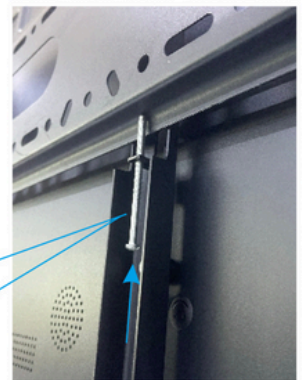
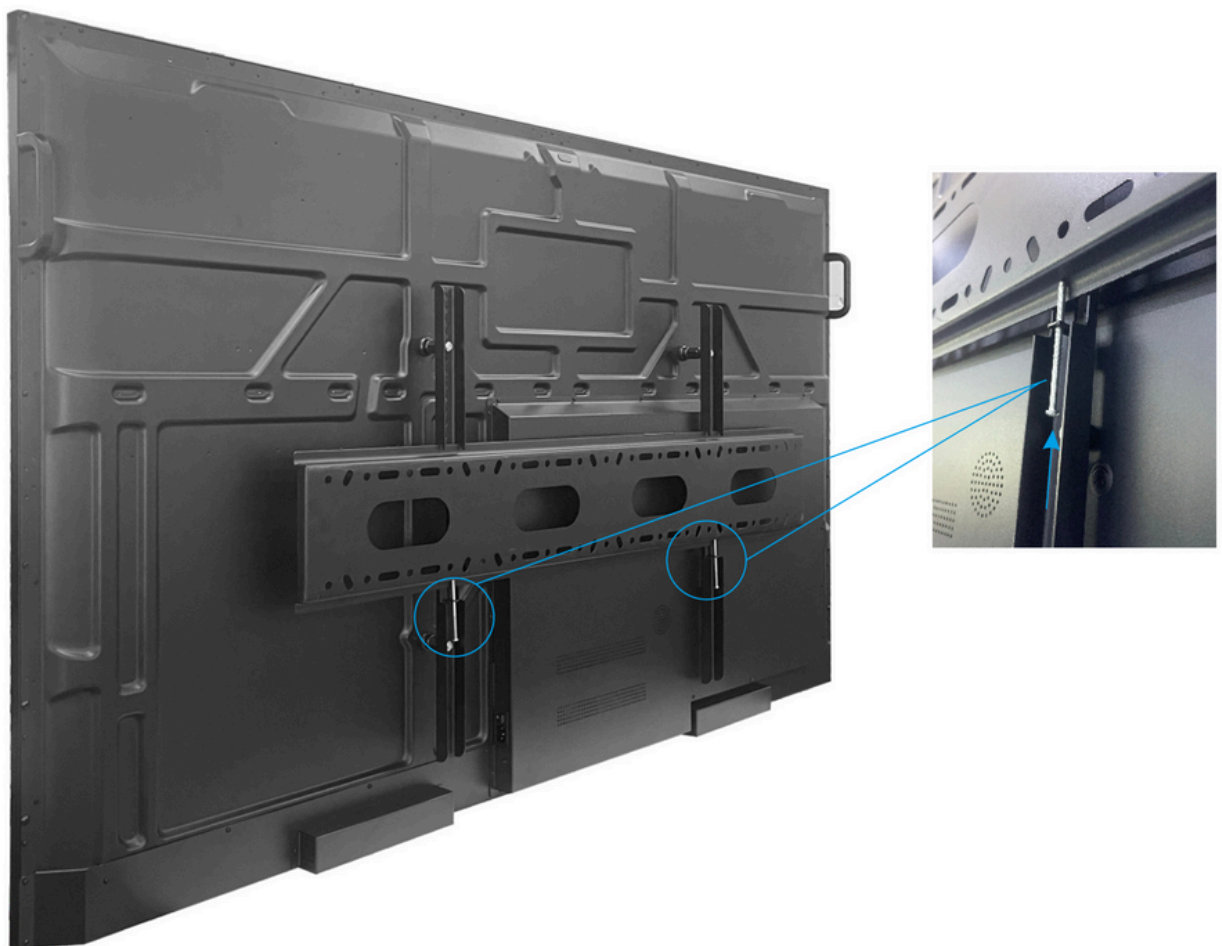

OPERATION

Power On/Off

- Start up by inserting the power cord into unit and connecting to outlet. Flip power switch to ON.
- Power on or off the screen, press the power button on the remote control.
- To shut down, press the power button on the remote control, then flip power switch to OFF.

The power indicator light turns green when the unit is on. When the unit is in standby mode, the light turns red.

HDMI Connection

1. Connect PC or media player via HDMI Port.
2. Open the HDMI in app (See next page for instructions on navigating applications). The HDMI input appears on screen.



HDMI-IN Port

Please Note: Some media players may not be supported.

To automatically display HDMI input upon device startup, open the HDMI Auto-boot app and use the toggle to enable auto-boot. This allows HDMI input to display instead of the Android operating system every time the unit is powered on.



HDMI Auto-boot





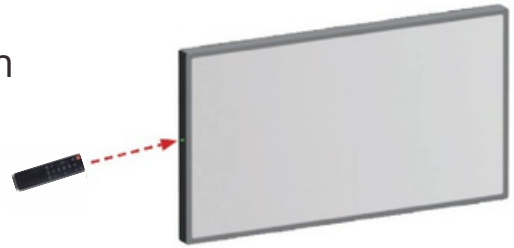









Remote Control

Important Notice: Before using the remote control, please remove the USB receiver from the battery compartment, insert it into the device's USB port, and then install two AAA batteries into the remote control.



Remote Control Functions

NOTE: Only the buttons listed below have supported function. For convenient navigation, we recommend connecting an external mouse and keyboard via usb ports.

Button	Function
	Power switch
	Open settings (This requires system or third-party software to design, currently unused in the system)
	Open signal source settings menu (This requires system or third-party software to design, currently unused in the system)
	Confirm selection
	Upward cursor
	Downward cursor
	Left cursor / Delete
	Right cursor
	Open the OSD menu settings (This requires system or third-party software to design, currently can be used by GTV media player)
	Return to previous menu; Press twice to exit media player (GTV)
	Mute
	Increase volume
	Decrease volume
	Mouse movement mode
	Return to home display page



NOTE: Above image for illustration purposes only

Menu Navigation

The home screen of the operating system includes the navigation bar and the App Drawer. The app drawer is a feature on Android operating systems that provides a central, organized location to view and launch all installed apps.

NOTE: The navigation bar can be minimized. To restore the navigation bar, go into Display settings and enable Display Navigation.

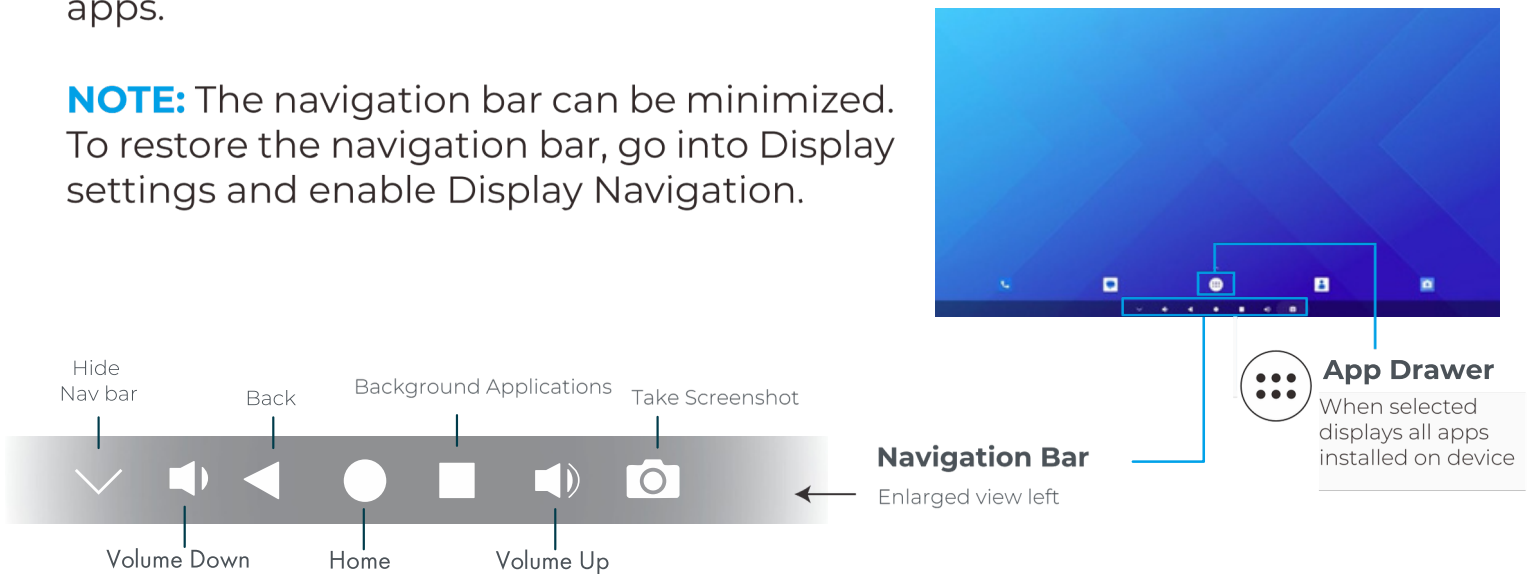

Quick Start Guide

The most convenient way to display content on your digital display is to use the pre installed app titled “Digital Signage Player” in “Single/ezPoster” mode. If the app does not load when the device is turned on, the app can be found amongst the list of apps in the app drawer.

If a program is available for playback, either from the device’s storage or a connected USB storage, it will start playing automatically. However, if no program is available, the home screen of the digital signage player will remain displayed, waiting for further action. Before running digital content, please ensure the player is set to Single/ezPoster mode.



NOTE: For more advanced operation features, please contact our customer support team

Quick Start Guide (Cont'd)

To ensure you have Digital signage player set to USB (Single) mode, please follow these steps;

1. Once the digital signage player home screen is displayed, Press the “menu” button on your remote to access the players settings.



2. Select “publishing mode”.

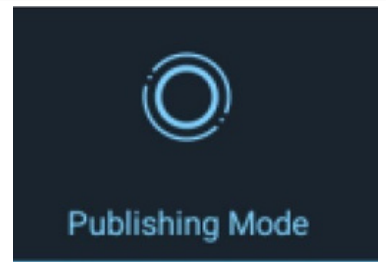

3. Select “Single/ezPoster”



4. Hit return (top left corner)
(At this stage, the software will reboot, a warning will appear).



5. Once reboot has occurred, insert usb with content. The app will copy content and ask you to remove usb.

6. Remove usb and let the system reboot. The content should play after start up.

Cleaning and Maintenance

- Avoid strong vibration or impact on the product.
- Keep the product dry to avoid possible damage by moisture.
- Don't place the product under direct sunlight which may shorten the service life of the screen.
- Clean screen and product by using a glass cleaner.
- If the product will not be used for a long time, unplug the power cord to prevent the internal short circuit or other potential dangers.

CAUTION: Do not attempt to replace or repair circuitry yourself. Contact customer service to schedule a professional further assistance.

Trouble Shooting Guide

ISSUE	PROBABLE CAUSE	SOLUTION
NO PICTURE OR SOUND	<ul style="list-style-type: none"> Unit not plugged into wall outlet Power cord not properly connected to the terminal on the back of the unit Unit not powered on Wall outlet not working 	<ul style="list-style-type: none"> Check that the unit is plugged into wall outlet. Confirm that the power cord is connected to the terminal on the back of the unit. Turn the on/off toggle switch located on the back of the unit. Unplug unit, wait 20 seconds, plug unit back into outlet and try again. Make sure that outlet is working by plugging in a different electrical device.
NO SOUND	<ul style="list-style-type: none"> Volume not adjusted on the remote control Content/Video does not have sound Content format is not compatible Speakers do not work 	<ul style="list-style-type: none"> Adjust volume using the remote control. Confirm content file is one of the compatible audio or video file formats (see technical specifications). If unit is connected to Wi-Fi, use a test video such as those on YouTube and play video that has sound. Unplug unit, wait 20 seconds, plug unit back into outlet and try again. Try playing the content on a different device (smart phone, computer or tablet).
NO PICTURE	<ul style="list-style-type: none"> Content file damaged Content format is not compatible Screen damaged or defective 	<ul style="list-style-type: none"> Confirm content is one of the following compatible formats: AVI, MPEG4, WMV, MKV, flv, MP3, MP4, MOV. Try playing the content on a different device (smart phone, computer or tablet). Unplug unit, wait 20 seconds, plug unit back into outlet and try again.
REMOTE CONTROL NOT WORKING	<ul style="list-style-type: none"> Batteries not inserted properly Batteries are dead Standing too close or too far from the unit 	<ul style="list-style-type: none"> Check that battery is inserted properly with positive and negative orientation. Insert new batteries. Stand within 1 foot of the remote sensor on the side of the unit and point the remote directly at the sensor (see Remote Control instructions).
NO WI-FI SIGNAL	<ul style="list-style-type: none"> Wi-Fi is not turned on in settings Wi-Fi is not connected to a network Low or no signal from the router Antenna is missing or not properly attached Damaged PC board 	<ul style="list-style-type: none"> Check that Wi-Fi is turned on in settings Confirm that the antenna is correctly installed. Check that other devices are receiving the signal. If other devices are not receiving the Wi-Fi signal, please contact your internet service provider. Unplug or reset the router and wait for 20 seconds. Restart the router and check.
PARTS MISSING OR DAMAGED	<ul style="list-style-type: none"> Parts missing from product Parts damaged by operator 	<ul style="list-style-type: none"> Contact a customer service representative for parts missed during manufacturing (no charge for replacements). Contact a customer service representative for parts lost or damaged by the customer (charge for replacements).
CANNOT UPLOAD CONTENT	<ul style="list-style-type: none"> Content format is not compatible Content files are too large Port being used is defective App used to play content is defective Android board is defective 	<ul style="list-style-type: none"> Confirm content is one of the compatible image, video, or audio formats. Confirm file size is less than available space. Confirm file size is less than available space.
PRE-INSTALLED APPS NOT WORKING	<ul style="list-style-type: none"> 'Digital Signage Player' incorrectly set up Software error App is defective Android board is defective 	<ul style="list-style-type: none"> Turn off device and boot up again Check that file has successfully transferred from USB Contact support for further assistance.

If all the potential solutions have been tested for a particular issue and problems have not been resolved, contact a customer service representative for guidance.



1300 658 808



www.slimlinewarehouse.com.au



support@slimlinewarehouse.com.au