

LOW VOLTAGE, LONG
LASTING, EDGE LIT LED
TECHNOLOGY

DOUBLE SIDED
ELLIPTICAL LIGHT PANEL

SNAP SIDE RAILS FOR
EASY GRAPHIC CHANGES

ILLUMINATED TOTEM:
DOUBLE SIDED ELLIPTICAL

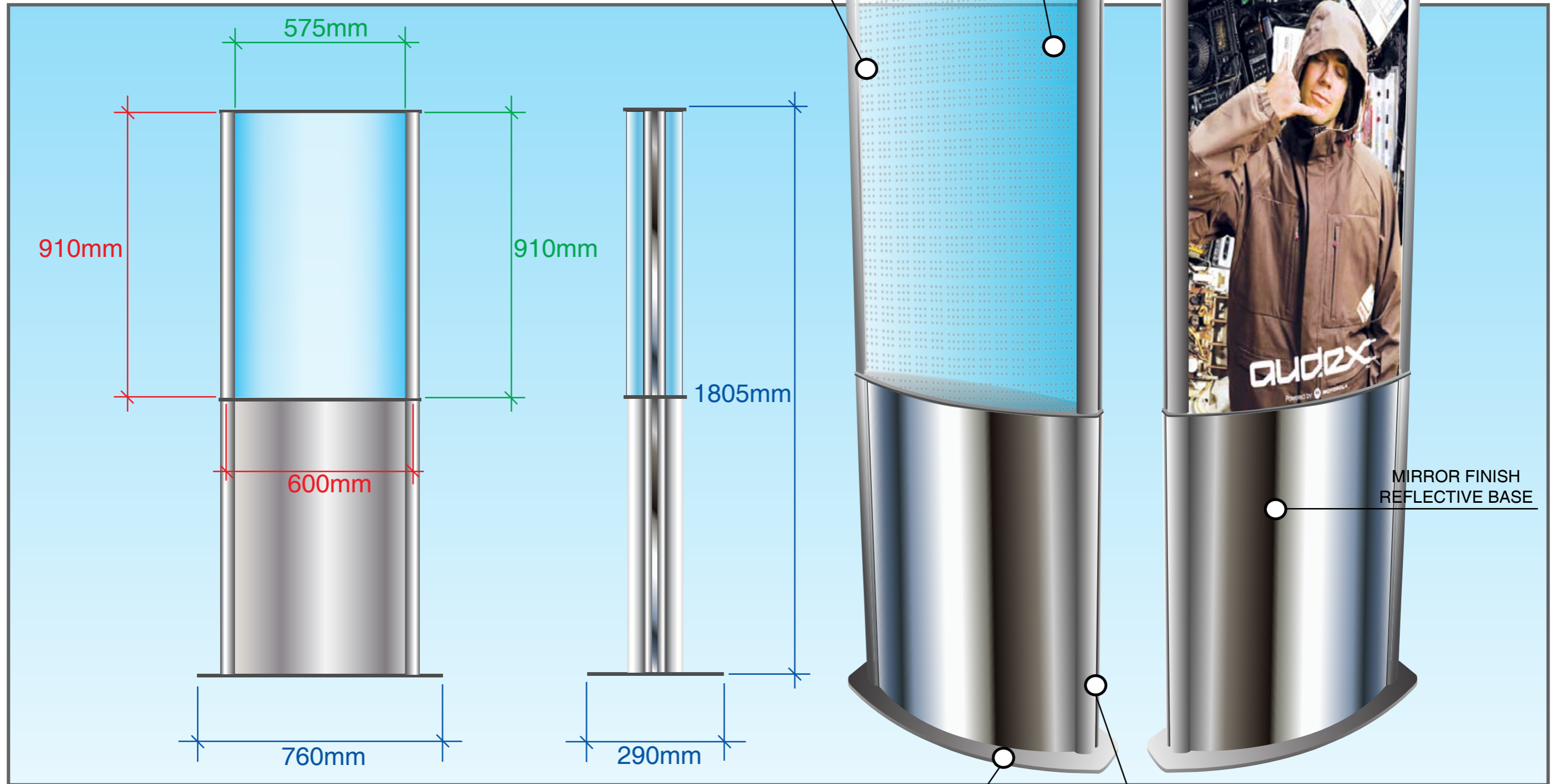

5MM BASE PLATE
SITS FLAT ON THE FLOOR

DURABLE LIGHTWEIGHT
ALUMINIUM FRAME

slimline
warehouse
THE CS&G GROUP

T +61 3 9359 9144 / +61 3 9359 5495

F +61 3 9359 9211

E sales@slimlinewarehouse.com.au

35 - 37 Sages Rd Glenroy VIC 3046 Australia

www.slimlinewarehouse.com.au